

## Tocador de barbería / Styling unit / Coiffeuse-barbier

ES

El tocador Oke transforma el ambiente de la barbería en un espacio único y bien distribuido. Su estética moderna aporta autenticidad y calidez al local, permitiendo mantener las herramientas y productos organizados de forma ordenada.

### ESTRUCTURA

1. Fabricado en tablero de aglomerado de alta densidad de 18 mm, libre de formaldehídos, recubierto con melamina con acabado madera y canteado en PVC de 2 mm.
2. Espejo plateado con arista pulida y molduras.
3. Vitrinas expositoras, cajoneras y puertas. (Ver opciones en la página siguiente).
4. Cerámica en color blanco o negro.
5. Cristal protector contra el agua.
6. Kit de desagüe completo (opcional) con cesta antipelo y grifo monomando.

EN

The Oke barber station transforms the barbershop environment into a unique and well-organized space. Its modern aesthetic adds authenticity and warmth to the shop while allowing tools and products to be neatly arranged.

### STRUCTURE

1. Made of 18 mm high-density particle board, formaldehyde-free, coated with wood-finish melamine and edged with 2 mm PVC.
2. Silver mirror with polished edge and mouldings.
3. Display cabinets, drawers and doors. (See options on the following page).
4. Ceramic basin available in white or black.
5. Protective glass panel against water.
6. Complete drainage kit (optional) with hair strainer basket and single-lever mixer tap.

FR

La coiffeuse Oke transforme l'ambiance du barber shop en un espace unique et bien organisé. Son esthétique moderne apporte authenticité et chaleur au salon tout en permettant de garder les outils et les produits parfaitement rangés.

### STRUCTURE

1. Fabriqué en panneau de particules haute densité de 18 mm, sans formaldéhyde, recouvert de mélamine finition bois et chanté en PVC de 2 mm.
2. Miroir argenté avec arête polie et moulures.
3. Vitrines d'exposition, tiroirs et portes. (Voir les options à la page suivante).
4. Céramique disponible en blanc ou noir.
5. Verre de protection contre l'eau.
6. Kit d'évacuation complet (en option) avec panier anti-cheveux et robinet mitigeur.



### COLOR · COLOR · COULEUR



### EMBALAJE · PACKAGING · EMBALLAGE



Cantidad de bultos  
Number of packages  
Nombre de colis

6

A\_96x50x14cm  
B\_96x50x16cm  
C\_150x55x13cm

D\_118x41x10cm  
E\_118x76x7cm  
F\_148x12x12cm

### DETALLES · DETAILS · DÉTAILS



### MEDIDAS · MEASUREMENTS · MESURES



140 cm



54 cm



202,7 cm



85,90 Kg

### PESO · WEIGHT · POIDS

## Medidas / Dimensions / Dimensions

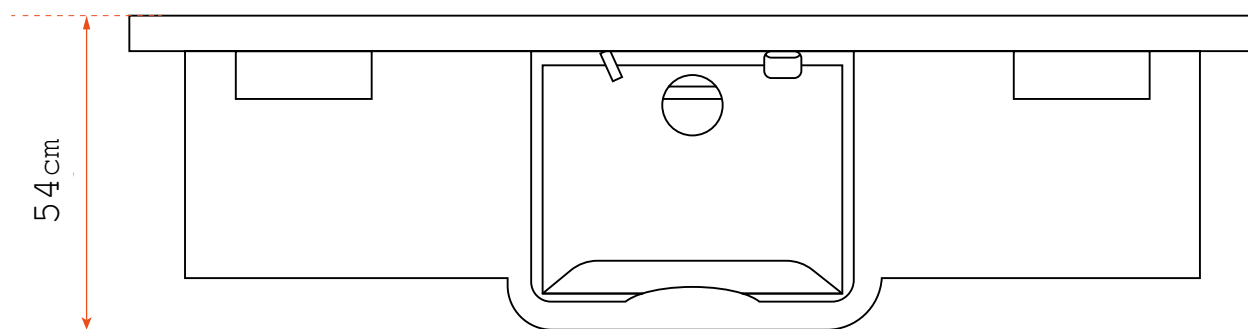
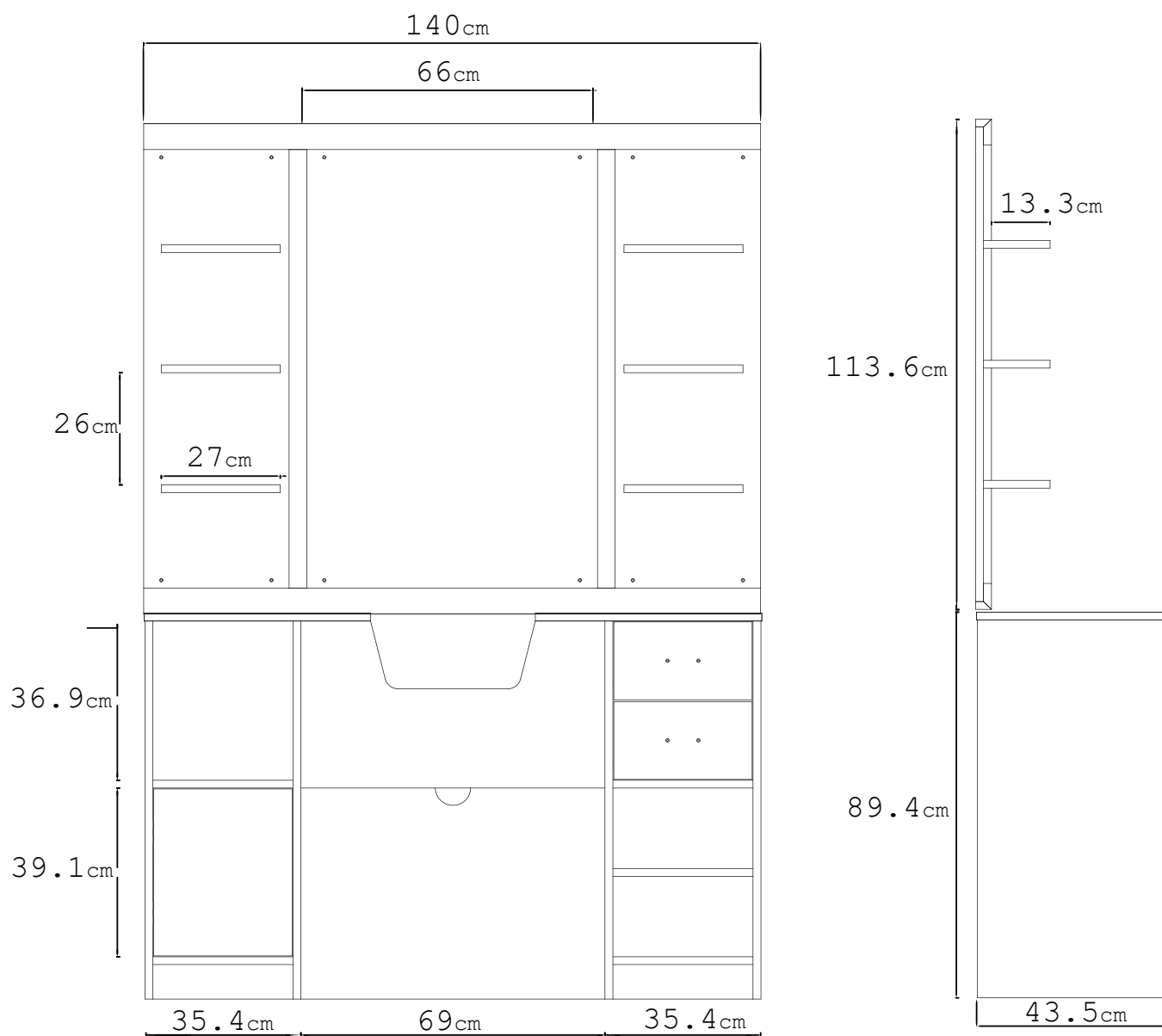

Combinaciones / Combinations / Combinaisons

Oke 3 98



Styling unit



Oke 3 B



Styling unit



Oke 3 BR



Styling unit



Oke 4 98



Styling unit  
Shampoo unit  
(Black /White)



Oke 4 B



Styling unit  
Shampoo unit  
(Black /White)



Oke 4 BR



Styling unit  
Shampoo unit  
(Black /White)



Oke 6 98



Styling unit  
Rounded Mirror



Oke 6 B



Styling unit  
Rounded Mirror



Oke 6 BR



Styling unit  
Rounded Mirror



Combinaciones / Combinations / Combinaisons

### Oke 8 98

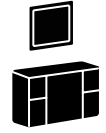

Styling unit  
Square Mirror



### Oke 8 B

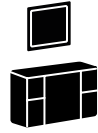

Styling unit  
Square Mirror



### Oke 8 BR



Styling unit  
Square Mirror



### Oke 2 98



Styling unit  
Rectangle Mirror  
Showcase  
Shampoo unit  
(Black / White)



### Oke 2 B



Styling unit  
Rectangle Mirror  
Showcase  
Shampoo unit  
(Black / White)



### Oke 2 BR



Styling unit  
Rectangle Mirror  
Showcase  
Shampoo unit  
(Black / White)



### Oke 1 98



Styling unit  
Rectangle Mirror  
Showcase



### Oke 1 B



Styling unit  
Rectangle Mirror  
Showcase



### Oke 1 BR



Styling unit  
Rectangle Mirror  
Showcase



Combinaciones / Combinations / Combinaisons

Oke 7 98



Styling unit  
Rounded Mirror  
Shampoo unit  
(Black /White)



Oke 7 B



Styling unit  
Rounded Mirror  
Shampoo unit  
(Black /White)



Oke 7 BR



Styling unit  
Rounded Mirror  
Shampoo unit  
(Black /White)



Oke 9 98



Styling unit  
Square Mirror  
Shampoo unit  
(Black /White)



Oke 9 B



Styling unit  
Square Mirror  
Shampoo unit  
(Black /White)



Oke 9 BR



Styling unit  
Square Mirror  
Shampoo unit  
(Black /White)



Fotografías del producto / Product photos / Photographies du produit



## Información importante / Important Information / Informations importantes Informació important / Wichtige Informationen / Informazioni importanti

### ES

#### INFORMACIÓN

Lea todas las instrucciones antes de comenzar el ensamblaje. Guarde las instrucciones para uso futuro. Uso interior.

#### ADVERTENCIA

Utilizar solo como se pretende.

#### MONTAJE

Seguir las instrucciones de montaje adjuntas.

#### MANTENIMIENTO

Periódicamente se deben realizar tareas de mantenimiento revisando el estado del producto. Verifique que el producto esté en buen estado y funcionando. Compruebe si hay roturas periódicamente. Retire el producto del servicio cuando se produzca alguna condición que pueda considerarse insegura.

#### CUIDADO Y LIMPIEZA

Limpie la unidad con un paño húmedo o una esponja con agua tibia y jabón suave. Séquelo. No use limpiadores abrasivos, blanqueadores, solventes químicos ni detergentes fuertes.

#### GARANTÍA

Consultar Condiciones Generales de Venta

### CAT

#### INFORMACIÓ

Llegeixi totes les instruccions abans de començar l'assemblatge. Guardeu les instruccions per a un futur ús. Ús interior.

#### ADVERTÈNCIA

Utilitzeu només segons el previst.

#### MUNTATGE

Seguiu les instruccions de muntatge adjuntes.

#### MANTENIMENT

S'han de realitzar tasques de manteniment periòdiques revisant l'estat del producte. Verifiqueu que el producte estigui en bon estat i funcioni correctament. Comproveu si hi ha trencaments periòdicament. Retireu el producte de l'ús quan es presenti alguna condició que pugui considerar-se perillosa.

#### CUIDAT I NETEJA

Netegeu la unitat amb un drap humit o una esponja amb aigua tèbia i sabó suau. Eixugueu bé. No utilitzeu netejadors abrasius, lleixius, solvents químics ni detergents forts.

#### GARANTIA

Consulteu les Condicions Generals de Venda

### EN

#### INFORMATION

Read all instructions before beginning assembly. Keep the instructions for future use. Indoor use.

#### WARNING

Use only as intended.

#### ASSEMBLY

Follow the attached assembly instructions.

#### MAINTENANCE

Periodic maintenance tasks should be performed by checking the condition of the product. Ensure the product is in good condition and functioning properly. Check for breaks regularly. Remove the product from service when any condition that could be considered unsafe occurs.

#### CARE AND CLEANING

Clean the unit with a damp cloth or sponge using warm water and mild soap. Dry thoroughly. Do not use abrasive cleaners, bleach, chemical solvents, or strong detergents.

#### WARRANTY

Please refer to the General Terms and Conditions of Sale

### DE

#### INFORMATIONEN

Lesen Sie alle Anweisungen, bevor Sie mit dem Zusammenbau beginnen. Bewahren Sie die Anweisungen für die zukünftige Verwendung auf.

#### WARNUNG

Nur wie vorgesehen verwenden.

#### MONTAGE

Befolgen Sie die beiliegenden Montageanleitungen.

#### WARTUNG

Regelmäßige Wartungsarbeiten sollten durchgeführt werden, indem der Zustand des Produkts überprüft wird. Stellen Sie sicher, dass das Produkt in gutem Zustand ist und ordnungsgemäß funktioniert. Überprüfen Sie regelmäßig auf Brüche. Entfernen Sie das Produkt aus dem Gebrauch, wenn eine Bedingung vorliegt, die als unsicher angesehen werden kann.

#### PFLEGE UND REINIGUNG

Reinigen Sie die Einheit mit einem feuchten Tuch oder Schwamm mit warmem Wasser und mildem Seifenreiniger. Trocknen Sie gründlich ab. Verwenden Sie keine Scheuermittel, Bleichmittel, chemische Lösungsmittel oder starke Reinigungsmittel.

#### GARANTIE

Allgemeine Verkaufsbedingungen beachten

### FR

#### INFORMATIONS

Lisez toutes les instructions avant de commencer l'assemblage. Conservez les instructions pour une utilisation future. Utilisation intérieure.

#### AVERTISSEMENT

Utiliser uniquement comme prévu.

#### ASSEMBLAGE

Suivez les instructions de montage ci-jointes.

#### ENTRETIEN

Des tâches d'entretien périodiques doivent être effectuées en vérifiant l'état du produit. Assurez-vous que le produit est en bon état et fonctionne correctement. Vérifiez régulièrement s'il y a des bris. Retirez le produit du service lorsqu'une condition pouvant être considérée comme dangereuse se présente.

#### ENTRETIEN ET NETTOYAGE

Nettoyez l'unité avec un chiffon humide ou une éponge à l'eau tiède et au savon doux. Séchez soigneusement. N'utilisez pas de nettoyeurs abrasifs, d'eau de Javel, de solvants chimiques ou de détergents puissants.

#### GARANTIE

Consulter les Conditions Générales de Vente

### IT

#### INFORMAZIONI

Leggere tutte le istruzioni prima di iniziare il montaggio. Conservare le istruzioni per un uso futuro. Uso interno.

#### AVVERTENZA

Utilizzare solo come previsto.

#### MONTAGGIO

Seguire le istruzioni di montaggio allegate.

#### MANUTENZIONE

È necessario eseguire periodicamente attività di manutenzione controllando lo stato del prodotto. Assicurarsi che il prodotto sia in buone condizioni e funzioni correttamente. Controllare periodicamente la presenza di rotture. Rimuovere il prodotto dall'uso quando si presenta una condizione che potrebbe essere considerata insicura.

#### CURA E PULIZIA

Pulire l'unità con un panno umido o una spugna con acqua tiepida e sapone neutro. Asciugare bene. Non utilizzare detergenti abrasivi, candeggina, solventi chimici o detergenti forti.

#### GARANZIA

Consultare le Condizioni Generali di Vendita



Futuras actualizaciones  
Future updates  
Mises à jour futures

Futures actualitzacions  
Zukünftige Aktualisierungen  
Aggiornamenti futuri



Calidad certificada  
Certified quality  
Qualité certifiée

Qualität zertifiziert  
Zertifizierte Qualität  
Qualità certificata



Mirplay colabora con la ong:  
Mirplay collaborates with ngo:  
Mirplay participe à l'ong:

Mirplay col·labora amb l'ong:  
Mirplay arbeitet mit der ngo zusammen:  
Mirplay collabora con l'ong: